



RM 65 DATA SHEET

CABLE DRIVER ADAPTER/BUFFER

RM 65

The RM 65 product line is designed for OEM and end user microcomputer applications requiring state-of-the-art performance, compact size, modular design and low cost. Software for RM 65 systems can be developed in R6500 Assembly Language, PL/65, BASIC and FORTH. Both BASIC and FORTH are available in ROM and can be incorporated into the user's system.

The RM 65 product line uses a motherboard interconnect concept and accepts any card in any slot. The 64-line RM 65 Bus offers memory addressing up to 128K bytes, high immunity to electrical noise and includes growth provisions for user functions. A selection of card cages provides packaging flexibility. RM 65 products may also be used with Rockwell's AIM 65 Microcomputer for product development and for a broad variety of portable or desktop microcomputer applications.

ORDERING INFORMATION

The Cable Driver Adapter/Buffer is available in an Edge Connector Version (RM65-7116) and a Eurocard version (RM65-7116E).

FEATURES

- RM 65 Bus compatible
- Buffered address data and control lines
- Drives up to 15 modules
- Long cable for distances of up to 6 feet
- Edge connector and Eurocard versions
- Fully assembled, tested and warranted

PRODUCT OVERVIEW

The Cable Driver Adapter/Buffer extends the RM 65 Bus from the AIM 65 Expansion Connector to a compatible motherboard that is situated up to six feet away. Included circuitry permits the Cable Driver Adapter/Buffer to drive up to 15 RM 65 Bus-compatible modules. (The similar Adapter/Buffer, Part Number RM65-7104, provides the same drive capability for applications in which the motherboard need not be more than 16 inches from the Expansion Connector.)

The Cable Driver Adapter/Buffer consists of a cable driver adapter module, a buffer module, and two 6-foot interconnect cables. Both cables are flexible, so the motherboard may be installed in a wide variety of locations and orientations relative to the AIM 65.

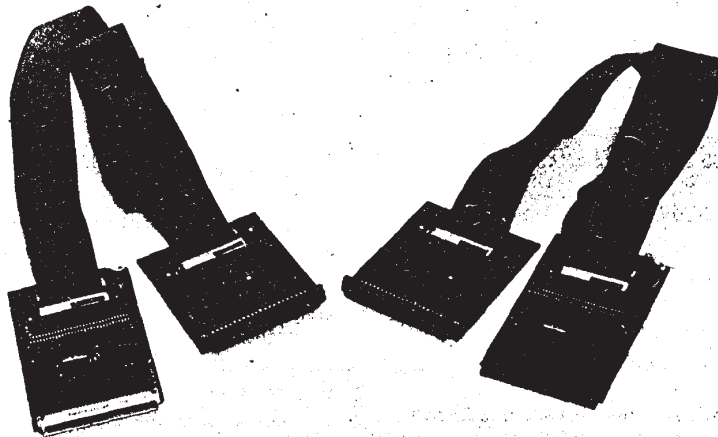

Eurocard Version
RM65-7116E

Edge Connector Version
RM65-7116

CABLE DRIVER ADAPTER/BUFFER

RM65
BOARD
PRODUCTS

FUNCTIONAL DESCRIPTION

The Cable Driver Adapter/Buffer consists of two modules and two interconnect cables. The Adapter Module connects to the AIM 65 Expansion connector and the Buffer module connects to an RM 65 Bus motherboard receptacle.

The Cable Driver Adapter module buffers data, address and control lines between the AIM 65 Expansion Connector and the interconnect cables.

The Data Transceivers drive 8-bits of parallel data. During a write operation, data received from the AIM 65 are driven onto the cables. During a read operation, data received from the cables are driven into the AIM 65. The bus active signal enables the Data Transceivers.

The Address Buffers drive 16-bits of parallel data from the AIM 65 onto the cables.

The Control Buffers transfer the timing and control signals between the AIM 65 and the cables. The seven read/write, clock, sync, and reset lines are driven from the AIM 65 onto the cables. The four ready, set overflow, interrupt request and non-maskable interrupt lines are driven from the cables onto the AIM 65.

Two 6-foot 40 conductor flat ribbon cables connect the Cable Driver Adapter module to the Buffer module. The cables are mass terminated at each end, and are permanently attached to the interfacing module.

The Buffer module buffers and routes all interface signals between the interconnect cables and the RM 65 Bus connector.

The Data Transceivers invert and drive 8-bits of parallel data. During a write operation, data received from the cables are driven onto the RM 65 Bus. During a read operation, data received from the RM 65 Bus are driven onto the cables. The bus active signal enables the Transceivers. When the bus float signal is active, the Transceivers are disabled.

The Address Buffers invert and transfer 16 parallel address lines from the interconnect cable to the RM 65 Bus. When the bus float signal is active, the Buffers are disabled.

Jumper E1 selects the source for the bank address line (BADR/) – either the buffer module or an external module. When the buffer module is the source (position A), the bank address line is held high to address Bank 0 (lower 65K) on the Bus; this line is disabled when the bus float line is active. For an external source (position B), the bank address line is not used by the buffer module, and must be controlled by another module on the Bus.

The seven read/write, clock, sync and reset lines from the cables to the bus are buffered by the Control Buffers. All of these lines, except reset and phase 1, are disabled when the bus float line is active. The ready, set overflow, interrupt request and non-maskable lines from the bus to the interconnect cables are also buffered by the Control Buffers.

Jumper E2 selects the source for the DMA Terminate line (BDMT/) – either the buffer module or an external module. When the buffer module is the source (position A), the DMA terminate line is held high (inactive). For an external source (position B), the DMA terminate line is not used by the buffer module, and must be controlled by another module on the bus.

INSTALLATION

Installing the Cable Driver Adapter/Buffer

Before installing the module, ensure that it is not damaged and is free of grease, dirt, liquid or other foreign material.

- a. Before installing the Cable Driver Adapter/Buffer, turn off power to the AIM 65 and the interfacing RM 65 Bus motherboard.
- b. Configure Jumpers E1 and E2, per the Functional Description.
- c. Align Cable Driver Adapter module connector J3 pin 1 with the AIM 65 Expansion Connector J3 pin 1.
- d. Plug the Cable Driver Adapter module onto the Expansion Connector. Press in firmly on the end of module until all pins are securely seated.
- e. Install connector P1 of the Buffer module into the desired slot on the mating RM 65 Bus motherboard.

CAUTION

RM 65 Bus connectors are keyed to prevent improper module connection. If the module does not insert into the receptacle with moderate pressure applied, check the orientation and connector alignment of the module. Forcing the module improperly into the receptacle may damage the receptacle and/or the module.

- f. Apply power to the AIM 65 and to the mating RM 65 Bus motherboard.

Removing the Cable Driver Adapter/Buffer

- a. Turn off power to the AIM 65 and to the RM 65 Bus motherboard.
- b. Lift up on the Buffer module ejector tab to release the module from the mating RM 65 Bus receptacle. Pull the module straight back until it is free from the card slot guides.
- c. Pull back on the Cable Driver module while moving it slightly from side to side until it is free from the AIM 65 Expansion Connector.

Buffer Module to RM 65 Bus Connector Pin Assignments

Bottom (Solder Side)				Top (Component Side)			
Signal Mnemonic	Signal Name	Input/Output	Pin	Pin	Signal Mnemonic	Signal Name	Input/Output
	Not Connected (See Note)		Wa	Wc		Not Connected (See Note)	
+5V	+5 Vdc Line (See Note)		Xa	Xc	+5V	+5 Vdc (See Note)	
GND	Ground		1a	1c	+5V	+5 Vdc	
BADR/	Buffered Bank Address	O	2a	2c	BA15/	Buffered Address Bit 15	O
GND	Ground		3a	3c	BA14/	Buffered Address Bit 14	O
BA13/	Buffered Address Bit 13	O	4a	4c	BA12/	Buffered Address Bit 12	O
BA11/	Buffered Address Bit 11	O	5a	5c	GND	Ground	
BA10/	Buffered Address Bit 10	O	6a	6c	BA9/	Buffered Address Bit 9	O
BA8/	Buffered Address Bit 8	O	7a	7c	BA7/	Buffered Address Bit 7	O
GND	Ground		8a	8c	BA6/	Buffered Address Bit 6	O
BA5/	Buffered Address Bit 5	O	9a	9c	BA4/	Buffered Address Bit 4	O
BA3/	Buffered Address Bit 3	O	10a	10c	GND	Ground	
BA2/	Buffered Address Bit 2	O	11a	11c	BA1/	Buffered Address Bit 1	O
BA0/	Buffered Address Bit 0	O	12a	12c	B ϕ 1	Buffered Phase 1 Clock	O
GND	Ground		13a	13c	BSYNC	Buffered Sync	O
BSO	Buffered Set Overflow	I	14a	14c	BDRQ1/	*Buffered DMA Request 1	
BRDY	Buffered Ready	I	15a	15c	GND	Ground	
	*User Spare 1		16a	16c	-12V/-V	*-12 Vdc/-V	
+12V/+V	*+12 Vdc/+V		17a	17c		*User Spare 2	
GND	Ground Line		18a	18c	BFLT/	Buffered Bus Float	I
BDMT/	Buffered DMA Terminate		19a	19c	B ϕ 0	*Buffered External Phase 0 Clock	
	*User Spare 3		20a	20c	GND	Ground	
BR \overline{W} /	Buffered Read/Write "Not"	O	21a	21c	BDRQ2/	*Buffered DMA Request 2	
	*System Spare		22a	22c	BR \overline{W}	Buffered Read/Write	O
GND	Ground		23a	23c	BACT/	Buffered Bus Active	I
BIRQ/	Buffered Interrupt Request	I	24a	24c	BNMI/	Buffered Non-Maskable Interrupt	I
B ϕ 2/	Buffered Phase 2 "Not" Clock	O	25a	25c	GND	Ground	
B ϕ 2	Buffered Phase 2 Clock	O	26a	26c	BRES/	Buffered Reset	O
BD7/	Buffered Data Bit 7	I/O	27a	27c	BD6/	Buffered Data Bit 6	I/O
GND	Ground		28a	28c	BD5/	Buffered Data Bit 5	I/O
BD4/	Buffered Data Bit 4	I/O	29a	29c	BD3/	Buffered Data Bit 3	I/O
BD2/	Buffered Data Bit 2	I/O	30a	30c	GND	Ground	
BD1/	Buffered Data Bit 1	I/O	31a	31c	BD0/	Buffered Data Bit 0	I/O
+5V	+5 Vdc		32a	32c	GND	Ground	
+5V	+5 Vdc (See Note)		Ya	Yc	+5V	+5 Vdc (See Note)	
	Not Connected (See Note)		Za	Zc		Not Connected (See Note)	

NOTE

Pins Wa, Wc, Xa, Xc, Ya, Yc, Za, Zc are not used on the Eurocard version.
 *Not used on this module.



RM65
BOARD
PRODUCTS

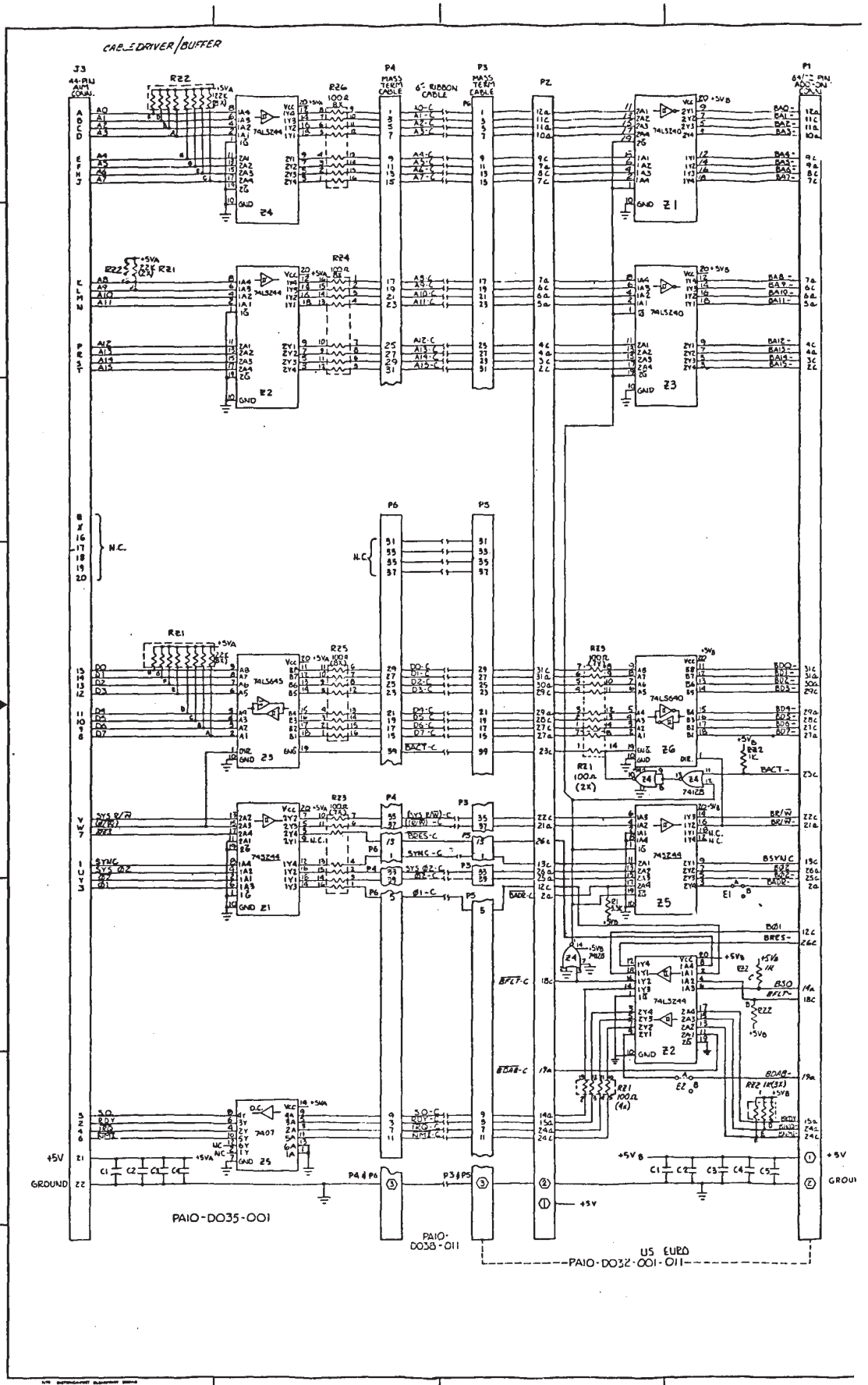

PAIO-DO35-001

PAIO-DO38-011

US EURO
PAIO-DO32-001-011

1/78 IMPROVED BOARD

RM65
BOARD
PRODUCTS

REVISIONS			
ZONE	LTR	DESCRIPTION	DATE APPROVED

NOTE: UNLESS OTHERWISE SPECIFIED

① PINS 1C, 32A ON EURO CONNECTOR AND PINS X₁₀, Y₁₀, Y₁₂, 1C, 32A ON U.S. CONNECTOR SHALL BE TIED TO +5V

② PINS 1A, 3A, 5C, 8A, 10C, 12A, 15T, 18A, 20C, 23A, 25T, 28A, 30C, 32A, SHALL BE TIED TO GND.

③ ALL EVEN NUMBER PINS (2 THRU 40) SHALL BE TIED TO GND.

4. ALL CAPACITORS ARE .10UF ±20%, 50V.

QTY REQD	QTY RECD	QTY REQD	QTY RECD	MEAS UNIT	ITEM NO.	PART OR IDENTIFYING NUMBER	NOMENCLATURE OR DESCRIPTION	ZONE

PAIO-X031

UNLESS OTHERWISE SPECIFIED TOLERANCES ON:		AUTHORIZATION NO.		MICROWELL INTERNATIONAL CORPORATION ELECTRONIC DEVICES DIVISION - MICROELECTRONICS DEVICES 2810 SHIRLANDS AVE., AMSTERDAM, CA 94508	
DECIMALS	ANGLES	OR BY		SCHEMATIC-ASSY CABLE DRIVER / BUFFER 16 SLOT CARD CAGE	
±.005	±.005	CHK BY	<i>Agustin C/11/10</i>		
		APPD BY	<i>Agustin C/11/10</i>		
MATERIAL:		APPD BY		SIZE	CODE IDENT
HEAT-TREAT				E	34576
FINISH				DRAWING NO.	PAIO-X031
APPLICATION				SCALE	1:1

This drawing is the property of MICROWELL INTERNATIONAL CORPORATION and is to be used only for the specific application and quantity authorized by MICROWELL INTERNATIONAL CORPORATION. It is not to be reproduced, copied, or distributed in any form without the written consent of MICROWELL INTERNATIONAL CORPORATION. The user of this drawing shall be held responsible for any damage or injury resulting from the use of this drawing.

Cable Driver Adapter Module to AIM 65 Expansion Connector Pin Assignments							
Top (Component Side)				Bottom (Solder Side)			
Signal Mnemonic	Signal Name	Input/Output	Pin	Pin	Signal Mnemonic	Signal Name	Input/Output
SYNC	SYNC	I	1	A	A0	Address Bit 0	I
RDY	Ready	O	2	B	A1	Address Bit 1	I
$\emptyset 1$	Phase 1 Clock	I	3	C	A2	Address Bit 2	I
\overline{IRQ}	Interrupt Request	O	4	D	A3	Address Bit 3	I
S.O.	Set Overflow	O	5	E	A4	Address Bit 4	I
\overline{NMI}	Non-Maskable Interrupt	O	6	F	A5	Address Bit 5	I
RES	Reset	O	7	H	A6	Address Bit 6	I
D7	Data Bit 7	I/O	8	J	A7	Address Bit 7	I
D6	Data Bit 6	I/O	9	K	A8	Address Bit 8	I
D5	Data Bit 5	I/O	10	L	A9	Address Bit 9	I
D4	Data Bit 4	I/O	11	M	A10	Address Bit 10	I
D3	Data Bit 3	I/O	12	N	A11	Address Bit 11	I
D2	Data Bit 2	I/O	13	P	A12	Address Bit 12	I
D1	Data Bit 1	I/O	14	R	A13	Address Bit 13	I
D0	Data Bit 0	I/O	15	S	A14	Address Bit 14	I
-12V	* -12 Vdc		16	T	A15	Address Bit 15	I
+12V	* +12 Vdc		17	U	SYS $\emptyset 2$	System Phase 2 Clock	I
$\overline{CS8}$	* Chip Select 8		18	V	SYS R/ \overline{W}	System Read/Write	I
$\overline{CS9}$	* Chip Select 9		19	W	R/ \overline{W}	Read/Write "Not"	I
\overline{CSA}	* Chip Select A		20	X	TEST	* Test	I
+5V	+5 Vdc		21	Y	$\emptyset 2$	Phase 2 Clock "Not"	I
GND	Ground		22	Z	RAM R/ \overline{W}	* RAM Read/Write	I

NOTE:
* = Not used on this module.

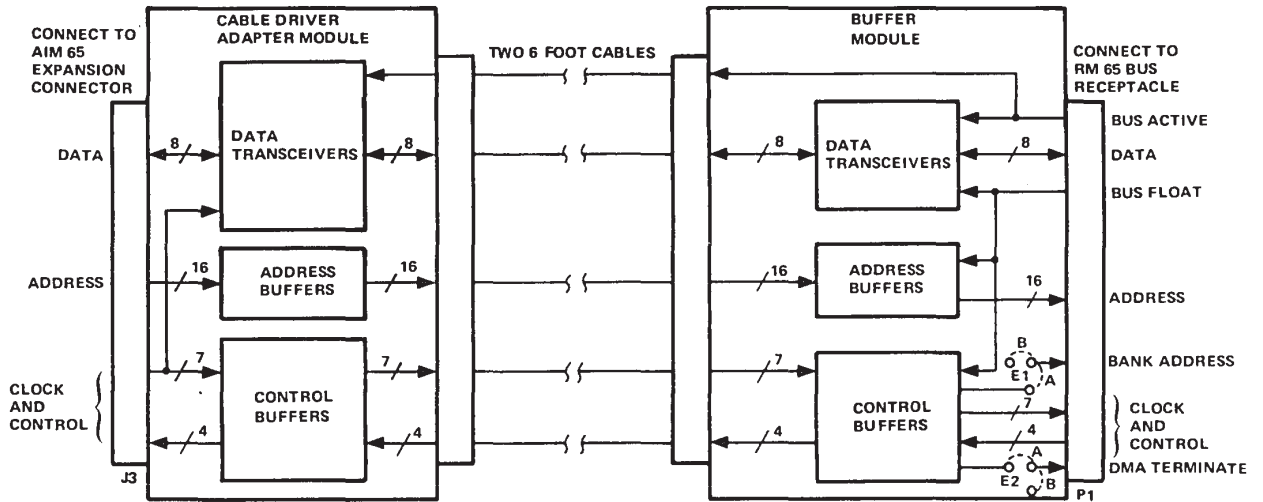

Cable Driver Adapter/Buffer Block Diagram

Cable Driver Adapter/Buffer Physical and Electrical Characteristics

Characteristics	Value
Dimension (See Notes)	
Cable Driver Adapter Module	
Width	4.4 in. (111 mm)
Length	5 in. (127 mm)
Height	0.56 in. (14 mm)
Buffer Module	
Edge Connector	Eurocard
Width	3.9 in. (100 mm)
Length	6.5 in. (164 mm)
Height	0.56 in. (14 mm)
Weight	1.0 lb (450 g)
Power	
Cable Driver Adapter Module	+5V \pm 5% 30 mA (0.15W) – Typical 275 mA (0.25W) – Maximum
Buffer Module	+5V \pm 5% 190 mA (0.95W) – Typical 330 mA (1.7W) – Maximum
Environment	
Operating Temperature	0°C to 70°C
Storage Temperature	-40°C to 85°C
Relative Humidity	0% to 85% (without condensation)
Propagation Time	50 ns – Maximum
Interface Connectors	
AIM 65 Expansion Connector	22/44 – edge receptacle (0.156 in. centers)
RM 65 Bus	
Edge Connector Version	72-pin edge connector (0.100 in. centers)
Eurocard Version	64-pin plug (0.100 in. centers) per DIN 41612 (Row b is not installed)
Interface Cables	
Number of Cables	Two
Cable Length	6 feet
Type	Flat ribbon
Number of conductors per cable	40
Wire Size	#28 AWG

NOTES:

1. The height includes the maximum values for component height above the board surface (0.4 in. for populated modules), printed circuit board thickness (0.062 in.), and pin extension through the bottom of the module (0.1 in.)
2. The length does not include extensions beyond the edge of the module due to connectors or the module ejector.
3. The Eurocard dimensions conform to DIN 41612.



CABLE DRIVER ADAPTER MODULE

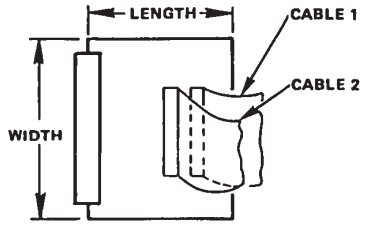

BUFFER MODULE

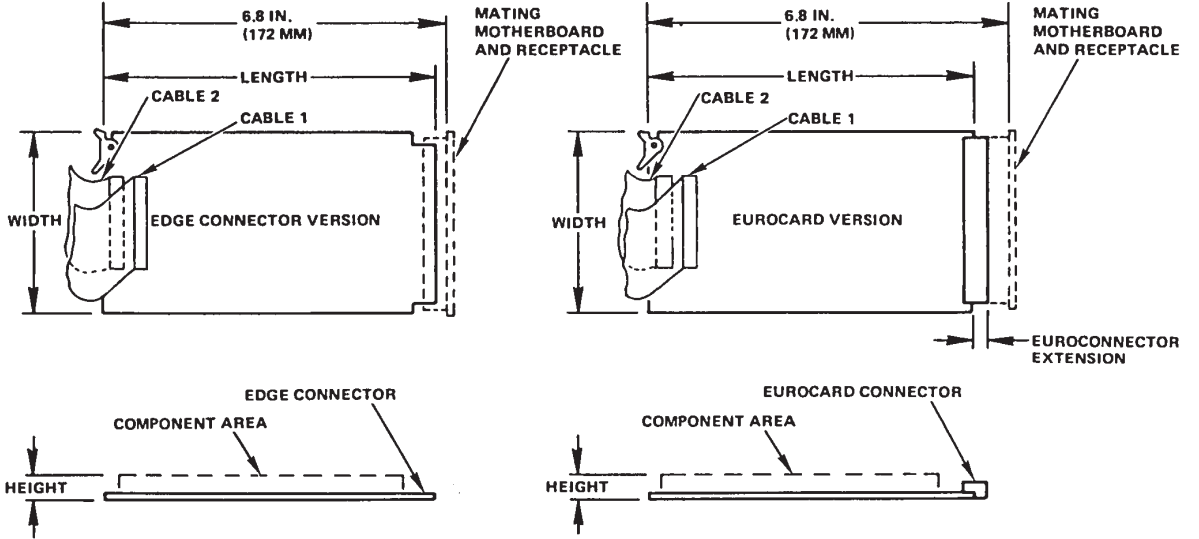

Module Dimensions