



RM 65 DATA SHEET

FLOPPY DISK CONTROLLER (FDC) MODULE

RM 65

The RM 65 product line is designed for OEM and end user micro-computer applications requiring state-of-the-art performance, compact size, modular design and low cost. Software for RM 65 systems can be developed in R6500 Assembly Language, PL/65, BASIC and FORTH. Both BASIC and FORTH are available in ROM and can be incorporated into the user's system.

The RM 65 product line uses a motherboard interconnect concept and accepts any card in any slot. The 64-line RM 65 Bus offers memory addressing up to 128K bytes, high immunity to electrical noise and includes growth provisions for user functions. A selection of card cages provides packaging flexibility. RM 65 products may also be used with Rockwell's AIM 65 Microcomputer for product development and for a broad variety of portable or desktop microcomputer applications.

PRODUCT OVERVIEW

The RM 65 Floppy Disk Controller (FDC) Module controls up to four standard (8") or mini- (5¼") floppy disk drives, single or double sided, soft sectored with either single density (FM) or double density (MFM) format. Software control of media density allows single or double density disks to be used in any connected drives.

Two DIP headers configure the FDC to interface with either standard or mini-floppy disk drives. An on-board jumper selects single or double sided drives and a switch disables on-board ROM. The FDC directly interfaces to most popular drives with only switch and/or header changes. Bank Select and Bank Select Enable switches allow the FDC module to be dedicated to one of two 65K memory banks or assigned common to both banks. The FDC module I/O can be assigned to any page (256 bytes) using a standard PROM if the ROM is deselected.

FEATURES

- Compact size — about 4" x 6¼" (100 mm x 160 mm)
- Edge Connector and Eurocard versions
- RM 65 Bus compatible
- Buffered address, data and control lines
- Supports single or double sided, standard or mini-floppy disk drives
- Controls up to four disk drives
- Interfaces directly to Shugart SA-850 or SA-450 disk drives, with user options for other popular floppy disk drives
- Supports single-density IBM 3740 (FM) or double-density IBM System 34 (MFM) formats
- DMA data transfer capability
- Supports interrupt-driven or polled operation
- Bipolar PROM Base Address decoding
- Switches or jumpers for
 - Bank Selection to one or two banks
 - Double or Single sided operation
 - Select or deselect ROM
 - Module disable
- On-board header configures I/O for 8" or 5¼" drive interface
- On-board Program ROM containing disk utility and file management functions
- Fully assembled, tested and warranted.

ORDERING INFORMATION

The Floppy Disk Controller Module is available in an Edge Connector version (RM65-5101) and a Eurocard version (RM65-5101E).

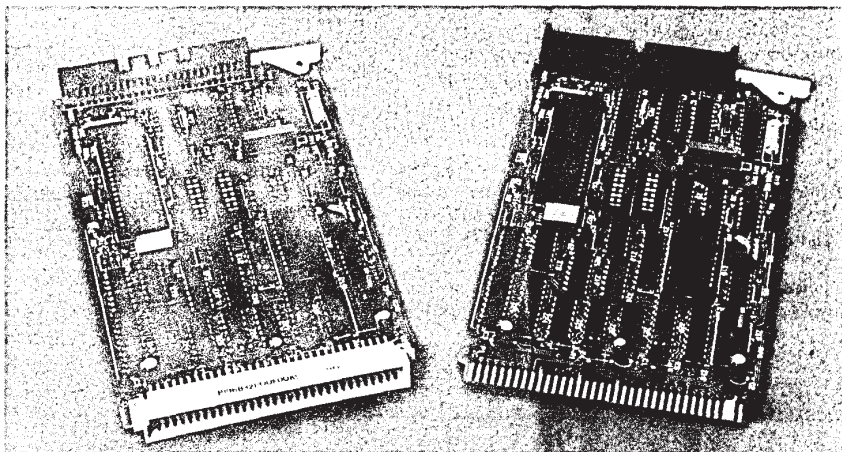

Eurocard Version
RM65-5101E

Edge Connector Version
RM65-5101

FLOPPY DISK CONTROLLER (FDC) MODULE



FUNCTIONAL DESCRIPTION

The Data Transceivers invert and transfer 8-bits of parallel data between the FDC module and the RM 65 bus, based on control signals from the Base Address Decoder and the Control Buffers. The read/write control line determines the direction, while the bus active enables the Data Transceivers.

The Address Buffers invert and transfer 12 of the 16 parallel address lines from the RM 65 bus to the Base Address Decoder, the Program ROM and the Floppy Disk Controller (FDC) device.

The Control Buffers invert and transfer phase 2 clock, reset, and read/write control signals from the RM 65 bus onto the module.

The Bank Select Control circuit detects when the module's assigned memory bank is addressed by comparing the bank address signal from the RM 65 bus to the Bank Select and Bank Select Enable switches. The Bank Select Enable switch assigns the module to be active in common memory (both Bank 0 and Bank 1) or only in the Bank set by the Bank Select switch (either Bank 0 or Bank 1).

The Interrupt and DMA Control circuit enables operation in either an interrupt driven mode or under DMA control. Both Interrupt generation and DMA requests can be disabled under program control. The DMA request is jumper selectable for either of two DMA request lines connected to the RM 65 bus.

The Base Address Decoder, with the Base Address Select PROM, the Bank Select Control circuit, the ROM Disable switch, and the phase 2 and read/write signals control device selection on the module. The Base Address Select PROM compares the eight most significant address lines to the programmed addresses to generate device select signals to the Program ROM and the I/O devices. The ROM Disable switch assigns the module to be active either in a 256 byte page (disabled) or in a 4K byte block (enabled). A separate Module Disable switch allows the entire module to be disabled.

When the ROM is disabled, only the I/O devices are active, in the 256 byte page that matches all eight Base Address Select bits. For the I/O devices, the three least significant address lines, along with the phase 2 clock and read/write control signals, drive register select lines to the FDC device, and device select lines to the Drive Status Buffer and Drive Control Register.

When the ROM is enabled, the module is active in the 4K byte block that matches the four most significant Base Address select bits. The program ROM is selected except when the address matches the four least significant Base Address Select bits, in which case the I/O device select lines are selected.

The Controller Clock derives a reference frequency for the FDC device from a crystal controlled oscillator. The frequency is 1 MHz or 2 MHz, depending on the Drive Configuration Header position.

The FDC device, in conjunction with the Data Separator and Precompensation Circuitry, interfaces the RM 65 bus to the Floppy Disk

medium. The circuitry supports 5¼" or 8", single or double sided disk drives, with choice of single or double density, soft sector formats. The FDC features powerful commands, including single or multiple record read/write with selectable record lengths. Write precompensation circuitry ensures reliable data recovery in double density formats. The Precompensation jumper selects precompensation on all tracks, only on tracks 44 and greater, or no precompensation at all.

The Drive Configuration header selects the I/O connector and FDC circuitry for either 5¼" mini-floppy or 8" standard floppy disk formats. The 50-pin I/O receptacle connects the FDC module to a mass terminated cable connected to the installed disk drives. A 34-pin cable and mating connector can be used to connect the 5¼" mini-floppy drives while a 50-pin cable and mating connector is needed to connect to the 8" floppy drives.

The Drive Status Buffer allows detection of the Drive Configuration header and Single/Double Sided Drive jumper positions, as well as selected density and side information.

The Drive Control Register provides control of the side and drive selection, motor on, head load, double density, and interrupt disable. The Active Side 0 Level jumper allows the use of various drives without modification.

The Ready State Generator provides wait states as required by the FDC device.

The Program ROM contains the firmware to support operations with up to four disk drives (single or double side, single or double density), including:

- Format a Disk
- Read or Write a Sector
- Seek or Verify Seek of a Track
- Re-zero the Head
- Read or Write Multiple Sectors
- Read or Write a Track
- Turn Motor On or Off
- Select or De-select any Drive
- Read I.D.
- Reset

Included file management routines support up to 44 files on any disk side, independent of the disk size or density. These routines include:

- Initialize or List a Directory
- Create, Delete, or Rename a File Name
- Open, Close, or Purge a File
- Read from or Write to a File
- Write a Modified Sector
- Copy File
- Copy Disk

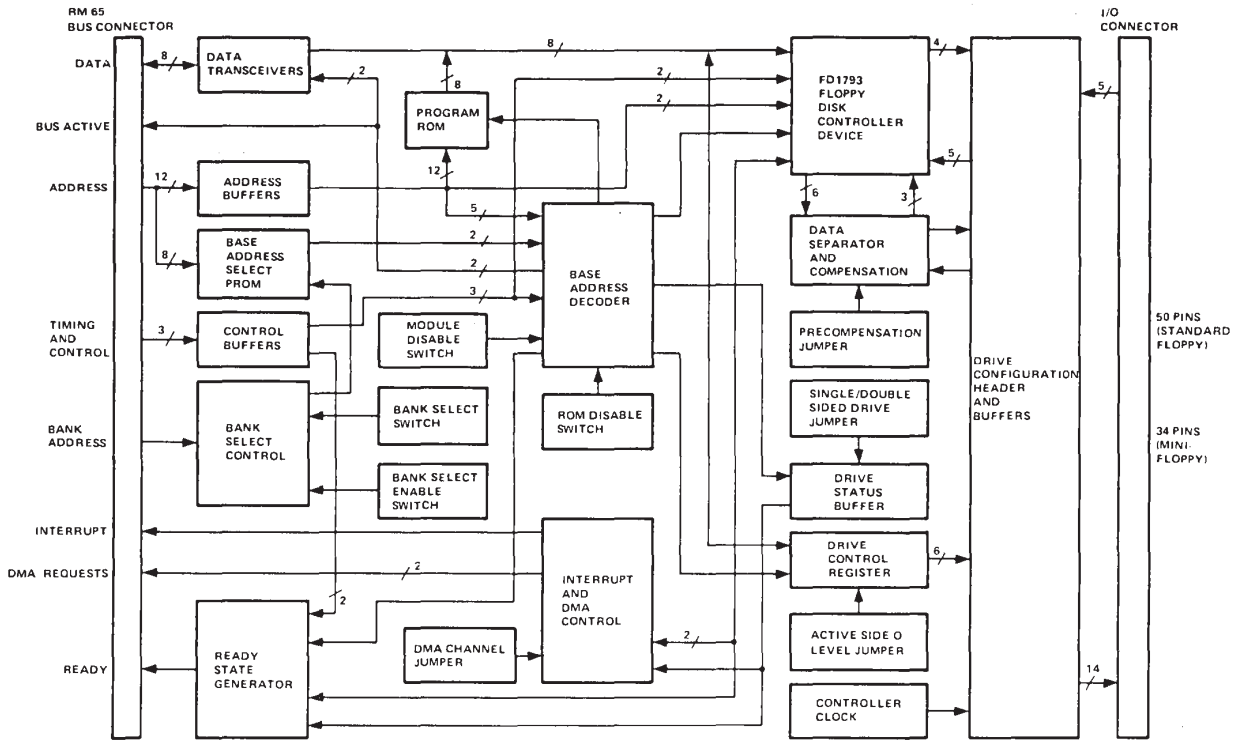

Floppy Disk Controller Module Block Diagram

I/O Connector Pin Assignments

FDC Module I/O Connector Pin	Standard Floppy Disk Drive Interface Cable Connector		Mini-Floppy Disk Drive Interface Cable Connector (2)	
	Pin	Signal Name	Pin	Signal Name
2	2	Track >43 (Remex & MFE or equivalents)		
4	4	N.C.		
6	6	N.C.		
8	8	Track >43 (Caldisk or equivalents)		
10	10	N.C.		
12	12	N.C.		
14	14	2nd Side Select		
16	16	N.C.		
18	18	Head Load	2	N.C.
20	20	Index	4	N.C.
22	22	Drive Ready	6	Drive Select #4
24	24	N.C.	8	Index
26	26	Drive Select #1	10	Drive Select #1
28	28	Drive Select #2	12	Drive Select #2
30	30	Drive Select #3	14	Drive Select #3
32	32	Drive Select #4	16	Motor On
34	34	Direction In	18	Direction In
36	36	Step Pulse	20	Step Pulse
38	38	Write Data	22	Write Data
40	40	Write Gate	24	Write Gate
42	42	Track Zero	26	Track Zero
44	44	Write Protected	28	Write Protected
46	46	Read Data	30	Read Data
48	48	N.C.	32	2nd Side Select
50	50	N.C.	34	N.C.

NOTES:

1. All odd numbered pins are GND.
2. Pin 1 of the 34-pin mini-floppy disk drive interface cable connector should be keyed to pin 17 of the FDC module I/O connector.



RM 65 Bus Pin Assignments

Bottom (Solder Side)			Top (Component Side)		
Signal Mnemonic	Signal Name	Pin	Pin	Signal Mnemonic	Signal Name
	Not Connected (See Note)	Wa	Wc		Not Connected (See Note)
+5V	+5 Vdc Line (See Note)	Xa	Xc	+5V	+5 Vdc (See Note)
GND	Ground	1a	1c	+5V	+5 Vdc
BADR/	Buffered Bank Address	2a	2c	BA15/	Buffered Address Bit 15
GND	Ground	3a	3c	BA14/	Buffered Address Bit 14
BA13/	Buffered Address Bit 13	4a	4c	BA12/	Buffered Address Bit 12
BA11/	Buffered Address Bit 11	5a	5c	GND	Ground
BA10/	Buffered Address Bit 10	6a	6c	BA9/	Buffered Address Bit 9
BA8/	Buffered Address Bit 8	7a	7c	BA7/	Buffered Address Bit 7
GND	Ground	8a	8c	BA6/	Buffered Address Bit 6
BA5/	Buffered Address Bit 5	9a	9c	BA4/	Buffered Address Bit 4
BA3/	Buffered Address Bit 3	10a	10c	GND	Ground
BA2/	Buffered Address Bit 2	11a	11c	BA1/	Buffered Address Bit 1
BA0/	Buffered Address Bit 0	12a	12c	B ϕ 1	* Buffered Phase 1 Clock
GND	Ground	13a	13c	BSYNC	* Buffered Sync
BSO	* Buffered Set Overflow	14a	14c	BDRQ1/	Buffered DMA Request 1
BRDY	Buffered Ready	15a	15c	GND	Ground
	* User Spare 1	16a	16c	-12V/-V	* -12 Vdc/-V
+12V/+V	+12 Vdc	17a	17c		* User Spare 2
GND	Ground Line	18a	18c	BFLT/	* Buffered Bus Float
BDMT/	* Buffered DMA Terminate	19a	19c	B ϕ 0	* Buffered External Phase 0 Clock
	* User Spare 3	20a	20c	GND	Ground
BR/ \bar{W} /	Buffered Read/Write "Not"	21a	21c	BDRQ2/	Buffered DMA Request 2
	* System Spare	22a	22c	BR/ \bar{W}	* Buffered Read/Write
GND	Ground	23a	23c	BACT/	Buffered Bus Active
BIRQ/	Buffered Interrupt Request	24a	24c	BNMI/	* Buffered Non-Maskable Interrupt
B ϕ 2/	Buffered Phase 2 "Not" Clock	25a	25c	GND	Ground
B ϕ 2	* Buffered Phase 2 Clock	26a	26c	BRES/	Buffered Reset
BD7/	Buffered Data Bit 7	27a	27c	BD6/	Buffered Data Bit 6
GND	Ground	28a	28c	BD5/	Buffered Data Bit 5
BD4/	Buffered Data Bit 4	29a	29c	BD3/	Buffered Data Bit 3
BD2/	Buffered Data Bit 2	30a	30c	GND	Ground
BD1/	Buffered Data Bit 1	31a	31c	BD0/	Buffered Data Bit 0
+5V	+5 Vdc	32a	32c	GND	Ground
+5V	+5 Vdc (See Note)	Ya	Yc	+5V	+5 Vdc (See Note)
	Not Connected (See Note)	Za	Zc		Not Connected (See Note)

NOTE

Pins Wa, Wc, Xa, Xc, Ya, Yc, Za and Zc are not used on Eurocard version.

*Not used on this module

Floppy Disk Controller (FDC) Module Physical and Electrical Characteristics

Characteristic	Value	
Physical Characteristics (See Notes)	Edge Connector	Eurocard
Width	3.9 in. (100 mm)	3.9 in. (100 mm)
Length	6.5 in. (164 mm)	6.3 in. (160 mm)
Height	0.56 in. (14 mm)	0.56 in. (14 mm)
Weight	4.8 oz. (135 g)	5.2 oz. (145 g)
Environment	0°C to 70°C	
Operating Temperature	-40°C to +85°C	
Storage Temperature	0% to 85% (Without condensation)	
Relative Humidity		
Power Requirements	+5 Vdc ±5% @ 600 mA – Typical 900 mA – Maximum	
	+12 Vdc ±5% @ 60 mA – Typical 100 mA – Maximum	
RM 65 Bus Interface		
Edge Connector Version	72-pin edge connector (0.100 in. centers)	
Eurocard Version	64-pin plug (0.100 in. centers) per DIN 41612 (Row b not installed)	
I/O Interface	50-pin mass terminated connector (0.100 in. centers) Mates with I&B/Ansley Part No. 609-5001M or equivalent	

NOTES:

1. The height includes the maximum values for component height above the board surface (0.4 in. for populated modules), printed circuit board thickness (0.062 in.), and pin extension through the bottom of the module (0.1 in.).
2. The length does not include the added extension due to the module ejector.
3. The Eurocard dimensions conform to DIN 41612.

RM65 BOARD PRODUCTS

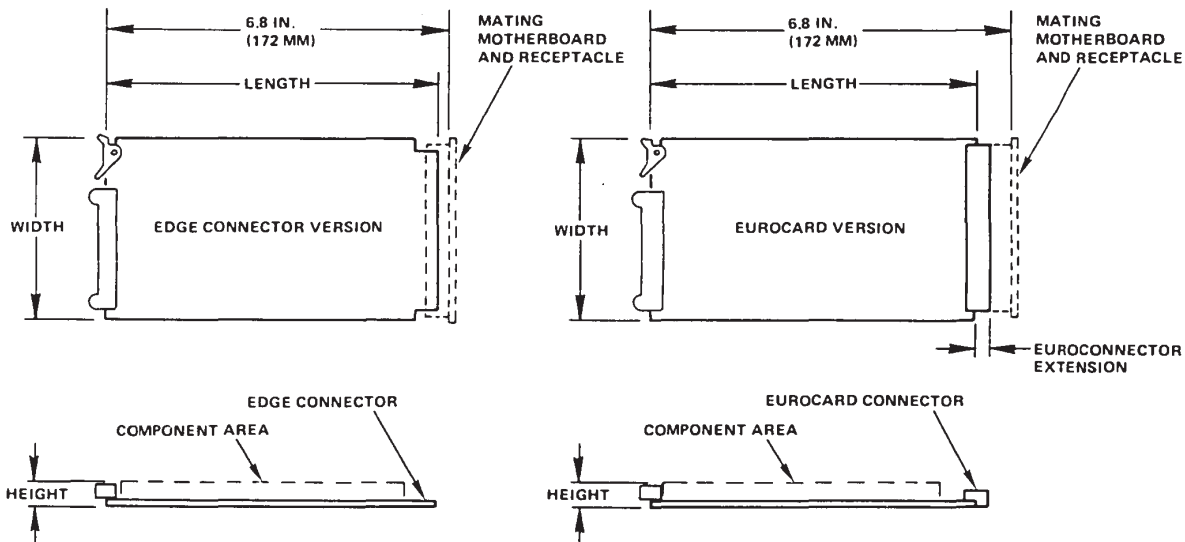

Module Dimensions

